THE GEORGE WASHINGTON UNIVERSITY

WASHINGTON, DC

SCHOOL OF ENGINEERING AND APPLIED SCIENCE
DEPARTMENT OF ELECTRICAL AND COMPUTER ENGINEERING
ECE 2110: CIRCUIT THEORY LABORATORY

Experiment #6:
Maximum Power Transfer Theory Applied to Lab Equipment

EQUIPMENT

<i>Lab Equipment</i>	<i>Equipment Description</i>
(1) DC Power Supply	Keysight E36311A Triple Output DC Power Supply
(1) Digital Multimeter (DMM)	Agilent 34460A (DMM)
(1) Breadboard	Prototype Breadboard
(3) Test Leads	Banana to Alligator Lead Set
(1) AA Battery	Standard AA 1.5V Battery

Table 1 – Equipment List

COMPONENTS

<i>Type</i>	<i>Value</i>	<i>Symbol Name</i>	<i>Multisim Part</i>	<i>Description</i>
Resistor	750 Ω	R _P	Basic/Resistor	---

Table 2 – Component List

OBJECTIVES

- Use maximum power transfer theory to measure the internal resistances of a DMM
- Use Thevenin theory to determine internal resistances of a DC battery and DC Power Supply
- Learn how to use maximum power transfer theory to determine internal resistance of an unknown piece of equipment

INTRODUCTION

Within all of the lab equipment you use, the DMM, the power supply, and even batteries, there are **internal resistances**. The equipment has been designed so that in most cases, your measurements will not be altered by the internal resistances of the equipment. However, there may be cases where the internal resistances of the equipment actually affect your measurements. As a practicing engineer, you must be aware of these internal resistances as a possible cause of error in your measurements. You must also learn how to measure such internal resistances so that you can work around these limitations if necessary.

This lab will introduce you to the internal resistances in the lab equipment you have encountered thus far in lab and teach you ways to measure them. In the lab, we use the Digital Multimeter (DMM) to measure voltage, current, and resistance. In each mode (V, A, Ω), there is a different internal resistance within the DMM. For each mode, the internal resistance is negligible and can ordinarily be ignored in our day-to-day measurements. However, there are limits for each mode of the DMM due to these internal resistances, which you must be aware of as you encounter and attempt to measure the various circuits you will build. These limits similarly apply to the DC power supply used in lab.

Maximum Power Transfer Theory

In order to achieve the **maximum load power** in a DC circuit, the load resistance must equal the driving resistance, that is, the internal resistance of the source (Thévenin resistance). Any load resistance value above or below this will produce a smaller load power. **System efficiency** (η), which can be defined as the ratio of load power to total power, is **50%** at the maximum power case. This is because the load and the internal resistance form a basic series loop, and as they have the same value, they must exhibit equal currents and voltages, and hence equal power dissipation. As the load increases in resistance beyond the maximizing value, the load voltage will rise; however, the load current will drop by a greater amount yielding a lower load power. Although this is not the maximum load power, this will represent a larger percentage of total power produced, and thus a greater efficiency (the ratio of load power to total power).

Any circuit can be thought of as a “black box” of sorts, where you may not know anything about the exact components it is made of or what it does. In many cases, you will be unable to access the internal circuitry of a device such as the DMM or power supply. From previous labs, we know that we can represent any circuit with its Thévenin equivalent circuit. The point at which the load resistance matches the internal resistance of the black box circuit (Thévenin resistance) is when maximum power transfer occurs, as shown below in **Figure 1**. This knowledge will prove to be extremely useful in attempting to determine the internal resistances of the equipment in the lab.

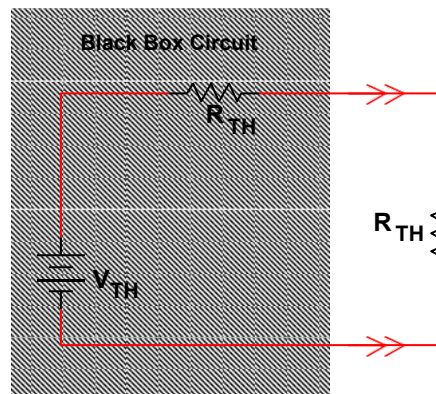

Figure 1 – Maximum Power Transfer

The DMM in Voltage Mode

When a DMM is set to measure voltage, a resistance internal to the DMM (R_V) is placed in **parallel** with the circuit it is measuring, as shown in **Figure 2**. Ideally, we would like R_V to be enormous, an open circuit in fact. Instead, it has a very large finite value. R_V draws a small amount of current from the circuit it measures, and the internal meter calculates the voltage across R_V , which is of course the voltage across the circuit one is measuring since R_V is in parallel with the circuit under test. Because R_V is large, it has little effect on the circuit one is measuring, unless R_V is close in size to the resistor being measured. The effect R_V has on the circuit being measuring is called “loading” because an additional load is placed on the circuit one is measuring. In this lab, we will determine R_V using **Maximum Power Transfer Theory**.

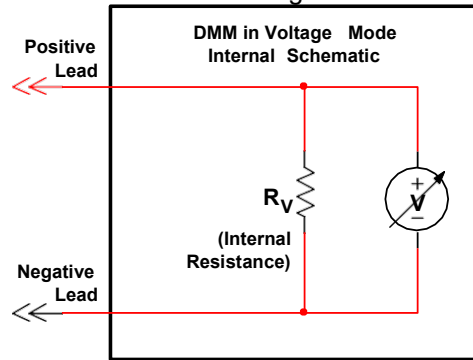

Figure 2 – DMM Reading Voltage

The DMM in Current Mode

When a DMM is set to measure current, an internal resistance (R_A) is placed in **series** with the circuit it is measuring. This is why we interrupt or break the circuit we are measuring current through. The current must flow into the meter through R_A . The schematic of the internals of the DMM in current mode is shown in **Figure 3**. Ideally, we would like R_A to be very small, a short circuit in fact. Instead, it has a small finite value. R_A allows all of the current from the circuit to flow into the meter and then back into the circuit one is measuring. Because R_A is very small, a very small amount of voltage is dropped across it, having little effect on the circuit one is measuring, unless R_A is close in size to the resistor one is measuring the current through. The effect of the internal resistor R_A has on the circuit one is measuring is called the resistance burden because it is burdening the circuit one is measuring. In this lab, we will measure R_A using **Maximum Power Transfer Theory**.

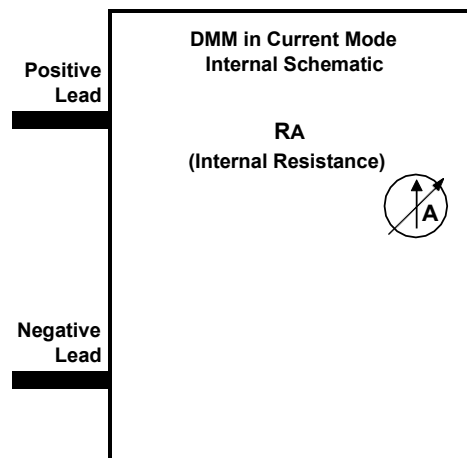

Figure 3 – DMM Reading Current

Regulated and Unregulated Voltage Sources

In class, the voltage sources we have studied do not have a current limit. No matter what resistance we attach to our theoretical voltage sources, the proper current is always supplied. However, any practical voltage source (battery, power supply, or generator) has internal resistances. These resistances limit the battery from producing infinite current. **Figure 4** shows the Thévenin equivalent circuit for any practical voltage source. While internally the voltage source may have a complicated configuration of current sources and resistances, they are all summed up in the Thévenin equivalent voltage source V_{TH} and resistance R_{TH} . The internal resistance of any power supply R_{TH} is designed to be as small as possible, from a few ohms to fractions of an ohm, so that little voltage drop occurs and the proper voltage is supplied to the circuit. In the lab, we will measure V_{TH} and R_{TH} of both the KEYSIGHT DC Power Supply and a battery.

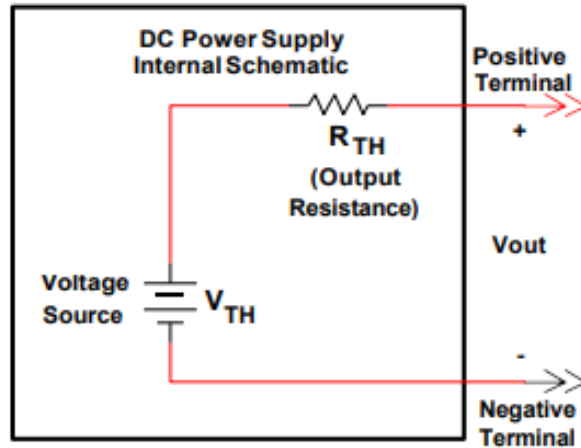

Figure 4 – DC Power Supply Thévenin Equivalent Circuit

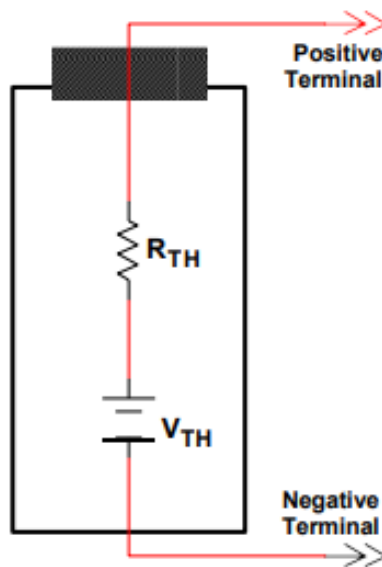

Figure 5 – Battery Thévenin Equivalent Circuit

PRELAB**Part I – Maximum Signal Transfer**

Figure P.1.1 – Problem #1

For the circuit in **Figure P.1.1**, V_S and R_S are fixed at the values shown in the schematic.

- For each value of R_L listed in the table, **hand calculate** V_{R_S} , V_{R_L} , I_{R_L} , and the power dissipated (or generated) by the voltage source, R_S , and R_L .
- Calculate** the system efficiency η using the data calculated in step 1.

R_S	R_L	V_{R_S}	V_{R_L}	I_{R_L}	P_{V_S}	P_{R_S}	P_{R_L}	η
1k Ω	0 Ω							
1k Ω	250 Ω							
1k Ω	500 Ω							
1k Ω	1k Ω							
1k Ω	1.25k Ω							
1k Ω	1.5k Ω							
1k Ω	2k Ω							
1k Ω	1M Ω							

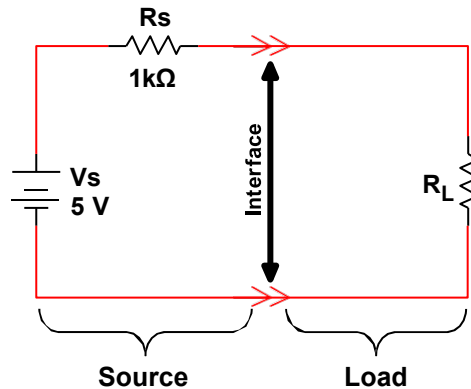
Table P.1.1 – Prelab Data Table 1

Answer the following questions regarding the table calculations:

- What value of R_L caused the highest amount of **current** in the circuit?
- What value of R_L caused the highest amount of **voltage** across the interface?
- What value of R_L caused the greatest amount of **power** to be transferred from the source to R_L ?
 - When this occurred, was $R_L < R_S$, $R_L = R_S$, or $R_L > R_S$?
 - When this occurred, what do you notice about the voltage drop across R_S and R_L ?
 - When this occurred, what do you notice about the current through the circuit, as compared to the maximum current in the circuit?
 - When this occurred, what is the system efficiency?
- Assume you have a circuit identical to that of **Figure P.1.1**. Assume now that you could not directly measure the voltage across R_S , and you do not know its value. Assume R_L was a potentiometer and you set up a DMM to measure the voltage across it. Could you determine the value of R_S ? If so, **explain** how you would do this.

Part II – Determining V_{TH} and R_{TH} Numerically

In **Part I** of this prelab, we were given the value of R_s (the resistance of the source) and the value of V_s (internal voltage of the source). However, we normally do not know the value of R_s or V_s , because these characteristics are contained within our power source. We only have the two terminals sticking out of the power source (positive and negative), so measuring R_s directly is not possible. We will now explore a method for finding R_s , which involves measuring the voltage and current coming out of our battery or power supply itself.

Consider the circuit setup in **Figure P.2.1** below. We do not know what V_{TH} or R_{TH} are inside the voltage source. However, we can attach different size resistors to the voltage source and measure I_L and V_L (the usefulness of these measurements will be explained shortly). For five possible values of R_L , we have measured values for I_L and V_L as shown in **Table P.2.1**.

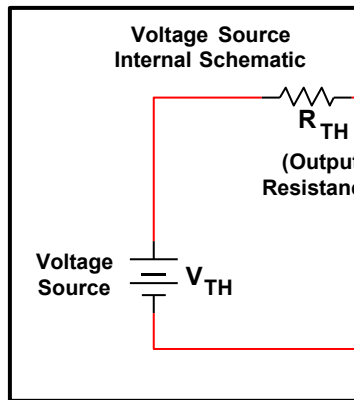

Figure P.2.1 – Circuit to Measure R_{TH}

R_L	I_L	V_L
10M Ω	0.0mA	5.000V
1k Ω	4.9mA	4.990V
500 Ω	9.9mA	4.985V
250 Ω	19.8mA	4.955V
100 Ω	49.0mA	4.920V

Table P.2.1 – Values of I_L and V_L for Various R_L

We need a way to relate the data we have collected back to the circuit we have in **Figure P.2.1**. We can easily use KVL to relate the values of R_{TH} and V_{TH} (our unknown variables) to R_L and V_L (our measured, known variables).

1. For this prelab problem, use **KVL** on the circuit in **Figure P.2.1** to generate an equation for the voltages in the loop in terms of the variables V_{TH} , R_{TH} , R_L , and V_L . For example, using Ohm's law, we know the voltage across the internal source resistor, $V_{R_{TH}} = R_{TH} \times I_L$, so we can eliminate $V_{R_{TH}}$ from our KVL equation.
2. The next step is to **solve the KVL equation** you have generated for V_L . You should have an equation that is of the form of a line (**$y=mx+b$** , where $y = V_L$, $m = R_{TH}$, etc).
3. Now, **use regression analysis** to find the approximate values of R_{TH} and V_{TH} . To do this, refer to the tutorial: **“Using MS Excel to solve a system of equations with linear regression”** that is on the lab website.

What to turn in for this problem:

1. Your KVL equation for the circuit in **Figure P.2.1** and all work getting it to be in $y=mx+b$ form.
2. A plot of the regression analysis you did in **Excel** showing the trendline, equation, and R^2 .
3. Using what you did in Excel, what is the value for R_{TH} in the circuit in **Figure P.2.1**?
4. From the data and circuit, we can see that we expect this to be a 5V battery. However, what load resistance R_L could we attach to this and get only 2.5V across it? Essentially, for what values of R_L would this battery **cease to look like a 5V battery**?

LAB

Part I – Determining the Internal Resistance of the DMM in Voltage Mode

In the prelab, we learned the DMM, when in voltage mode, appears to have a large internal resistance R_V in **parallel** with any circuit we are measuring. We wish to determine R_V by using what we learned about maximum power transfer from the prelab.

Note: You will be using multiple potentiometers throughout this lab. Their resistance values are extremely sensitive to touch, and proper care must be taken to obtain accurate measurements. It is usually easiest to measure the resistance of a potentiometer by disconnecting all wires attached to it, and measuring its resistance while it is actually still in the breadboard.

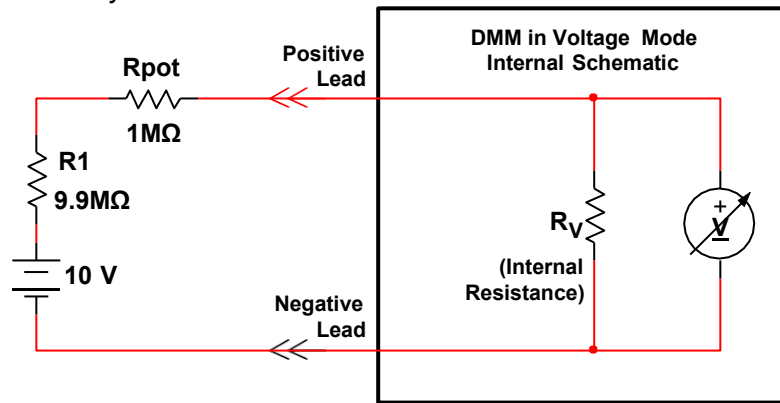

Figure 1.1 – Experimental Setup

1. **Set up** the circuit in **Figure 1.1**. For R_1 , use three $3.3M\Omega$ resistors in series.
2. **Attach** the negative terminal of the DMM to the negative terminal of the power supply and the positive terminal of the DMM to the potentiometer as shown above.
3. **Set** the DMM to voltage mode with auto-range enabled.
4. Initially, set R_{POT} to its **lowest value** and **record** the reading from the DMM as Initial V_{RPOT} .
5. Using what you have learned in the prelab, what value will the DMM read if you adjust R_{POT} so that $R_{POT} + 9.9M\Omega = R_V$? **Determine** this value and fill it into **Table 1.1**.
6. **Adjust** R_{POT} until you determine R_V , **record** the voltage reading as Final V_{RPOT} , and **measure** the value of R_{POT} .

Note: Remember you must disconnect R_{POT} from the circuit in order to measure it using the DMM in Ω mode.

<i>Initial V_{RPOT}</i>	<i>V at $R_L = R_V$</i>	<i>Final V_{RPOT}</i>	<i>R_{POT}</i>

Table 1.1 – DMM in Voltage Mode Data

Part II – Determining the Internal Resistance of the DMM in Current Mode

In the prelab, we learned the DMM, when in current mode, appears to have a small internal resistance R_A in **series** with any circuit we are measuring. We wish to determine R_A by using what we learned about maximum power transfer from the prelab.

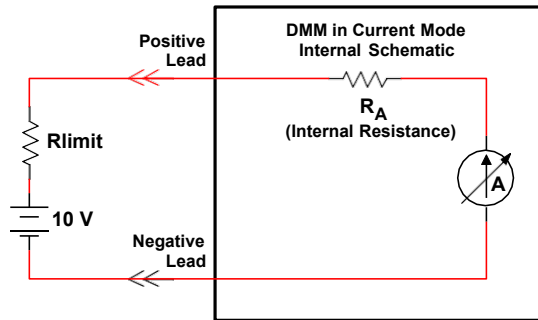

Figure 2.1 – Experimental Setup without Load

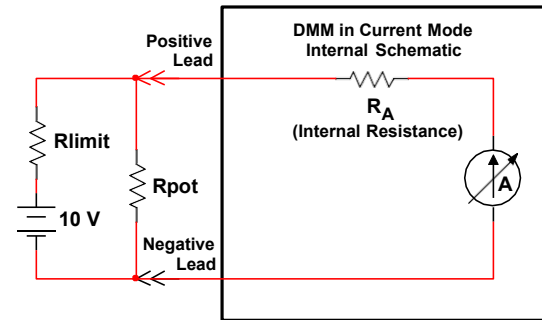

Figure 2.2 – Experimental Setup with Load

1. **Set up** the circuit in **Figure 2.1**, attaching the DMM to measure the current through R_{LIMIT} .
2. **Calculate** a value for resistor R_{LIMIT} in **Figure 2.1** using Ohm's law. The goal is to let **only** 50mA flow into the DMM. **Assume** R_A is 0Ω for this calculation.
Note: Because R_A is actually very small, a very large amount of current would flow into the DMM if a 10V source was applied to it directly. R_{LIMIT} limits the amount of current into the DMM to 50mA, which will protect the DMM from blowing a fuse.
3. **Record** the exact value of the current through R_{LIMIT} as I_{MAX} . Remember that the DMM does **not** have an auto-range button for measuring current.
4. **Attach** the smallest range potentiometer R_{POT} available in your kit as the circuit's load as shown in **Figure 2.2**. Set it to its highest value at first.
Note: Make certain to turn off the power supply when you make changes to the circuit.
5. **Adjust** the value of R_{POT} until the DMM reads $\frac{1}{2}$ of the I_{MAX} you found in Step 3.
6. **Turn off** the circuit, then disconnect and measure the **resistance** of R_{POT} .
7. This value of R_{POT} is **equal** to the value of R_A . **Why** is this true?

R_{LIMIT}	I_{MAX}	R_{POT}

Table 2.1 – DMM in Current Mode Data

Part III – Determining the Internal Resistance of an Unregulated Voltage Source (Battery)

In the prelab, we learned that any voltage source has some small internal resistance that limits its output current. We wish to determine the internal Thévenin voltage (V_{TH}) and resistance (R_{TH}) of a standard 1.5V AA Battery by using what we learned about maximum power transfer from the prelab.

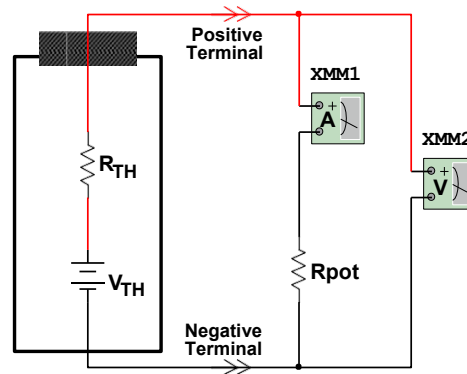

Figure 3.1 – Experimental Setup

1. **Set up** the circuit in **Figure 3.1**.
 - a. The DMM (in **current** mode, A) is represented by the multimeter **XMM1** in the schematic.
 - b. A **second** DMM (in **voltage** mode, V) is represented by **XMM2** in the schematic.
 - c. **Use** the **AA battery** supplied by your GTA as the source, note its rated voltage is 1.5V.
 - d. **Use** tape to secure wires to the AA battery.
 - e. **Initially**, use a **10MΩ** resistor for R_{POT} .
2. **Ensure** that the current meter reads **0A** with the 10MΩ resistor for R_{POT} .

Note: The value that the voltage meter now reads is the Thévenin equivalent voltage (V_{TH}). R_{POT} is so large that no current may flow through it or R_{TH} . The battery basically sees an open circuit.
3. **Record** the value from the DMM measuring voltage as V_{TH} .
4. **Replace** the 10MΩ resistor with a **500Ω** potentiometer for better precision in the next step.
5. **Lower** the value of the potentiometer until current begins to flow into R_{POT} (a few mA).
 - a. **Record** the current reading from the DMM in **Table 3.1**.
 - b. **Record** the voltage across R_{POT} in **Table 3.1**.
 - c. **Disconnect** R_{POT} and measure its resistance. A 3rd DMM may be useful here.
6. **Repeat** Step 5, lowering the potentiometer resistance until you draw about **50mA**.

Warning: Very low values of R_{POT} will cause a **large amount of current** to be drawn from the battery. **Do not lower** R_{POT} to values that draw more than 50mA as this will essentially short the terminals of the battery together, causing it to heat up, and **risk potential injury to you!**
7. **Record** the **voltage across** and the **current through** R_{POT} for each of these four values. Then, adjust the potentiometer to **four** points between the point where you draw 50mA and a few mA.
8. During your Post-Lab Analysis, **determine** R_{TH} using the **numerical method in Excel** outlined in **Part II** of the prelab.

R_{POT}	$I_{R_{POT}}$	$V_{R_{POT}}$

Table 3.1 – Unregulated AA Battery Data

Part IV – Determining the Internal Resistance of a Regulated Voltage Source (DC Power Supply)

The KEYSIGHT power supply is considered a **regulated** voltage source, as compared to a battery, because it has additional circuitry within it to maintain the desired voltage set by the user no matter the load applied across it. This makes it so that we must stress the power supply using very small resistances to determine the very small R_{THEV} internal resistance of this source.

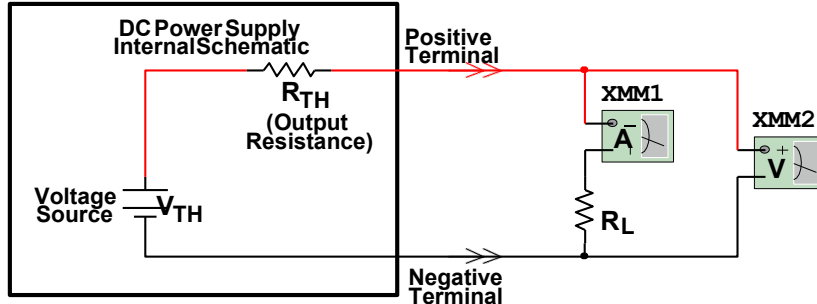

Figure 4.1 – Experimental Setup

Because a high degree of skill and parts not included in the ECE 2110 kit are required to take the measurements necessary in this part of the lab, the GTA will make the measurements for the entire class.

GTA: Use power resistors rated to at least **5W** and the **10A terminals** of the DMM for this part of the lab.

1. **Set up** the circuit in **Figure 4.1**.
 - a. The DMM (in **current** mode, A) is represented by the multimeter **XMM1** in the schematic.
 - b. A **second** DMM (in **voltage** mode, V) is represented by **XMM2** in the schematic.
 - c. **Use** the KEYSIGHT E36311A power supply as the source. Set the voltage to **3V**. Turn the voltage ‘off’ before attaching the next components.
2. **Start** by using **two 10MΩ** resistors in series (standard ¼ Watt resistors will work) for R_L . Have the students write down the voltage across it, and the current through it.
3. The value that the voltage meter now reads is the Thévenin equivalent voltage (V_{TH}). This is because R_L is so large that very little current may flow through it or R_{TH} . The power supply essentially sees an open circuit. **Record** V_{TH} .

4. **Replace** R_L with five different resistances: 10Ω, 5Ω, 3Ω, 2Ω, and 1Ω. Have the students write down the current through and voltage across R_L at each step.

Note: Because there are only 1Ω and 10Ω power resistors available in the lab, resistances of 1Ω, 2Ω, and 3Ω can be made by placing 1Ω power resistors in series, and a 5Ω resistance can be made by placing two 10Ω power resistors in parallel. Make the measurements **quickly**, as large amounts of current and high power dissipation will cause the power resistors to heat up very fast. Make certain to **turn off** the voltage when swapping R_L .

5. During your Post-Lab Analysis, **determine** R_{TH} using the **numerical method in Excel** outlined in **Part II** of the prelab. The value for R_{TH} will be extremely small (far less than 1Ω).

R_L	I_L	V_L
20MΩ		
10Ω		
5Ω		
3Ω		
2Ω		
1Ω		

Table 4.1 – Regulated Power Supply Data

POST-LAB ANALYSIS

1. **Complete** the following **table** of the internal resistances for each piece of lab equipment you have worked with in this lab and include it in your report. Keep it for future reference.

<i>Lab Equipment</i>	<i>Internal Resistance</i>
<i>Keithley 175 DMM in Voltage Mode</i>	
<i>Keithley 175 DMM in Current Mode</i>	
<i>1.5V AA Battery</i>	
<i>KEYSIGHT E36311A DC Power Supply</i>	

Table A.1 – Internal Resistances

2. Use the manual on the ECE 2110 lab website for the Keithley 175 to find the specified values for the internal resistances in voltage mode. This is typically referred to as “Input Resistance” in the manual because it is the resistance of the equipment looking “inward” towards the two terminals of the device.
3. For each piece of equipment, discuss the situations where the internal resistance will disrupt or give you inexact values for your measurements of circuits you may build in the lab. Give examples with numerical results to prove your point.
4. For **Part III** and **Part IV** of the lab, what is your margin of error (based on precision of the equipment, and R^2 from excel). **Explain** how you arrived at your calculation of error margin.